

Model 5 P Type Adjustable Professional Torque Wrench

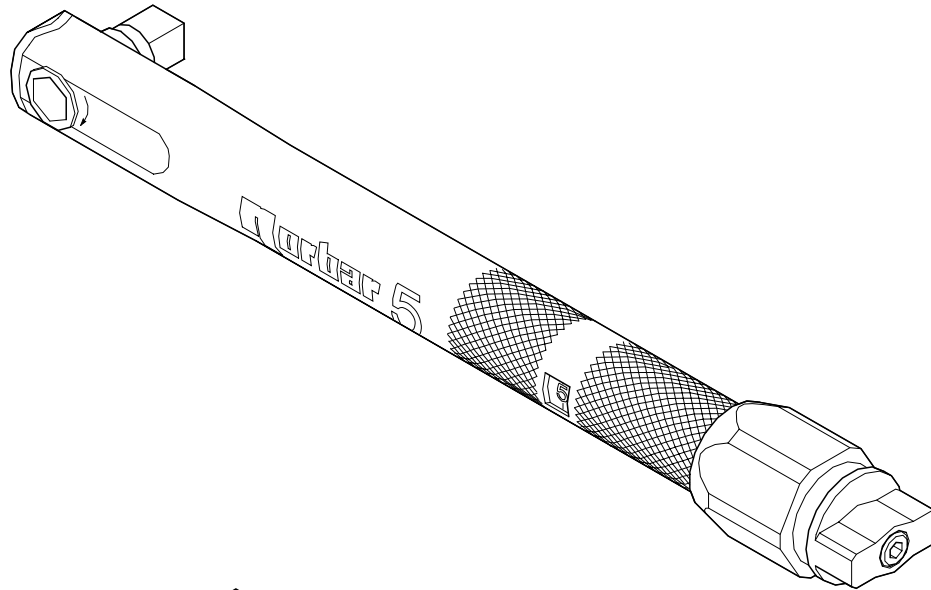

NORBAR TORQUE TOOLS LTD Beaumont Road, Banbury, Oxon. OX16 7XJ UNITED KINGDOM
Tel: +44 (0) 1295 270333 Fax: +44 (0) 1295 753643 <http://www.norbar.com>

Model 5 P Type Adjustable

PART No	QUANTITY	DESCRIPTION
13101	1	PRIMARY LEVER
13103	1	GUIDE ROLLER
13104	1	CHAIN LINK 8mm OUTER LINK PAIR
13105	1	TRANSVERSE LINK
13106	1	ADJUSTING SCREW
13107	1	ADJUSTING NUT
13108	1	INDEX COLLAR
13109	1	LOCK NUT
13111	1	END CAP
13112	1	THRUST WASHER
13114	1	GUIDE RING
13115	1	MICROMETER SCALE HOUSING
13116.BLK	2	CALIBRATION CAP-BLACK
13116.BLU	2	CALIBRATION CAP-BLUE
13116.GRN	2	CALIBRATION CAP-GREEN
13116.RED	2	CALIBRATION CAP-RED
13116.YEL	2	CALIBRATION CAP-YELLOW
13117	1	MICROMETER INDICATOR P TYPE
13118	1	ADJUSTING NUT RETAINER
13122	1	OPTIONAL - RATCHET ASSY-STEPLESS
13126	1	SCALE LENS
13127	1	BODY TUBE MDL 5 - SQ WINDOW
13128	1	DRIVE CENTRE 14 HEX THROUGH
25380S.6	1	BUT.HD SS M3x6LG WITH TUFLOK
26271	1	PIN GROOVED 2mm DIAx5 LONG
26519	2	WIRE RING FOR 1/4" HEX CENTRE
26520	1	CIRCLIP 1/4"DIA EXT
27019	4	STEEL BALL 3mm DIA 100 GRADE
28028	1	SPRING COMP. 3DIAx6.35x0.5WD
28071	1	SPRING COMP. 12.5 O/D x 42LG.
28900	1	ADAPTOR 1/4"HEX-1/4"SQ M/M