

Model 400 'P' Type 3/4" Industrial Ratchet

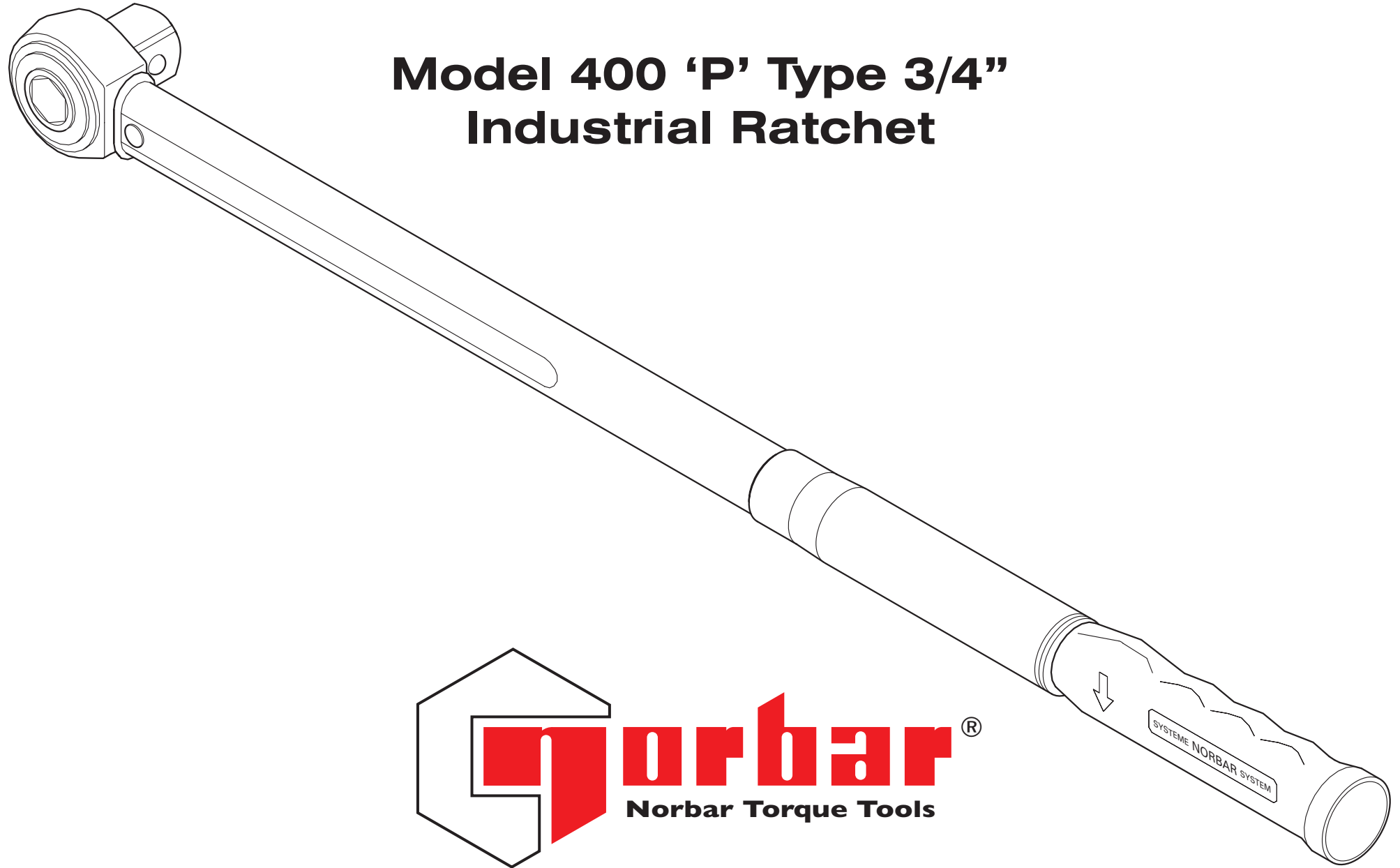

MODEL 400 'P' Type 3/4"

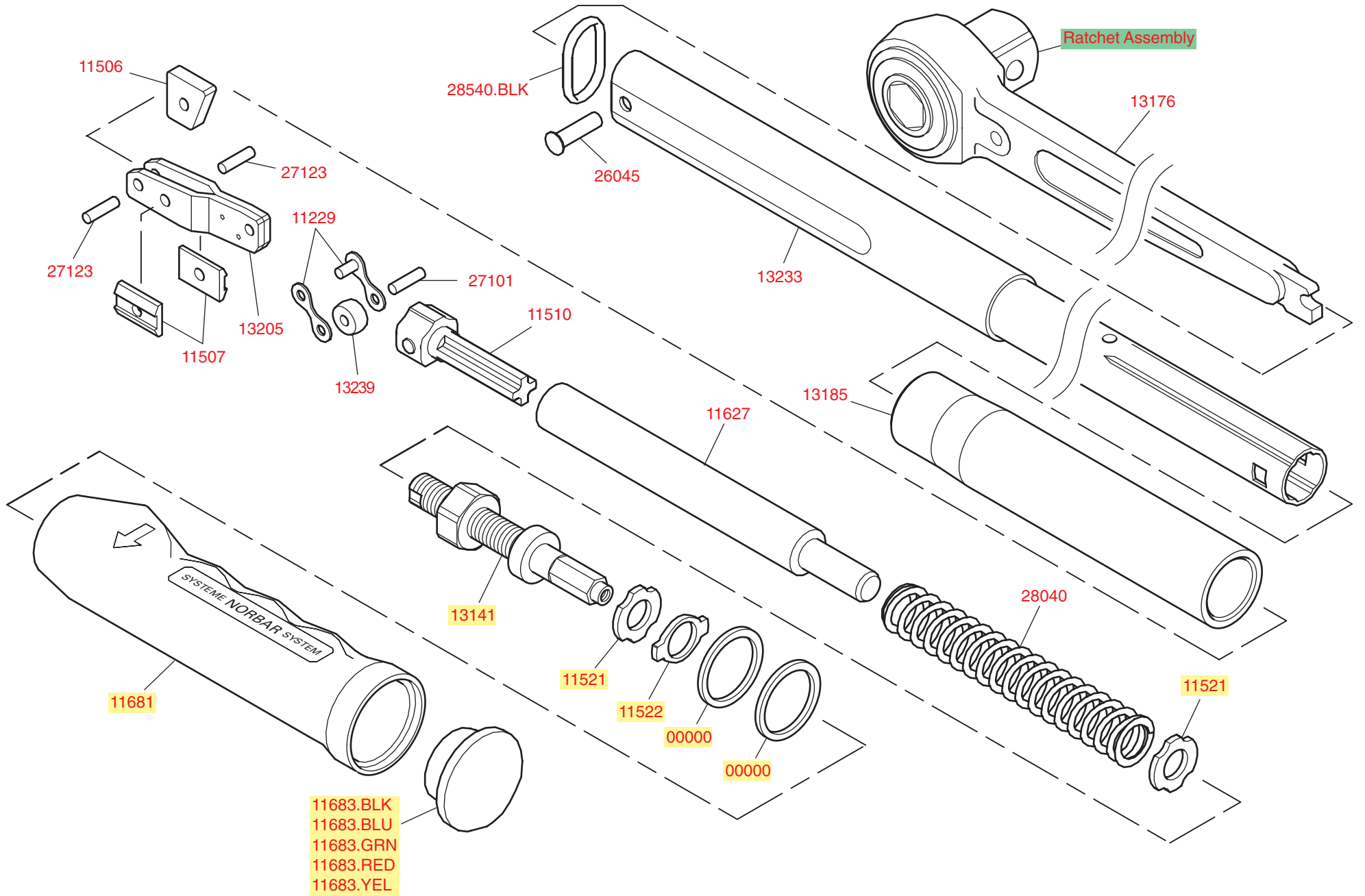

MODEL 400 'P' Type 3/4"

PART No	QUANTITY	DESCRIPTION
13239	1	ROLLER
11229	1	CHAIN LINK WITH PINS + LINK
11506	1	PIVOT BLOCK
11507	2	FRICTION PAD
11510	1	TRANSVERSE LINK
11521	2	SHAPED WASHER
11522	1	END STOP
11627	1	SPACER
11681	1	PRESS ON HANDLE
11683.BLK	2	DOMED HANDLE END CAP BLACK
11683.BLU	2	DOMED HANDLE END CAP BLUE
11683.GRN	2	DOMED HANDLE END CAP GREEN
11683.RED	2	DOMED HANDLE END CAP RED
11683.YEL	2	DOMED HANDLE END CAP YELLOW
13141	1	ADJUSTING SCREW
13176	1	RATCHET ASSEMBLY MODEL 400 3/4" SQUARE DRIVE
13185	1	ADJUSTING SCREW HOUSING
13205	1	SECONDARY LEVER ASSEMBLED
13233	1	MODEL 400 BODY TUBE ASSEMBLY
26045	1	PIN PIVOT
27101	1	NEEDLE ROLLER 3.5mm DIA x 13.6mm
27123	2	NEEDLE ROLLER 4mm x 15.8mm LONG
28040	1	SPRING 16.51mm DIA x 97.53mm LONG
28540.BLK	1	BLACK VITON 'O' RING BS 114
*****	2	'O' RING