

NORBAR JOINT SIMULATION RUNDOWN FIXTURES



CONTENTS

Part Numbers Covered by This Manual	1
Introduction	2
Part Number 50313 (0.2 – 2 N·m, 2 – 25 lbf·in)	3
Washer Make up for Various Joint Conditions	3
Operation Procedure	3
Graph Showing Torque Rate Curves for Various Washer Make-ups	4
Part Number 50251 (2 - 10 N·m, 20 – 100 lbf·in)	5
Washer Make up for Various Joint Conditions	5
Operation Procedure	5
Graph Showing Torque Rate Curves for Various Washer Make-ups	6
Part Number 50252 (5 – 50 N·m, 5 – 50 lbf·ft)	7
Washer Make up for Various Joint Conditions	7
Operation Procedure	7
Graph Showing Torque Rate Curves for Various Washer Make-ups	8
Part Number 50253 & 50693 (10 - 140 N·m, 10 – 100 lbf·ft)	9
Washer Make up for Various Joint Conditions	9
Operation Procedure	9
Graph Showing Torque Rate Curves for Various Washer Make-ups	10
Part Number 50254 50694 (100 - 700 N·m, 100 – 500 lbf·ft)	11
Washer Make up for Various Joint Conditions	11
Operation Procedure	11
Graph Showing Torque Rate Curves for Various Washer Make-ups	12
Bolt and Hex Drive Sizes	13
Spare Washer Stacks	13

PART NUMBERS COVERED BY THIS MANUAL

Part Number	Description	Square Drive
50313	0.2 - 2 N·m (2 - 25 lbf·in) for use with Bench Stands	¼"
50251	2 - 10 N·m (20 - 100 lbf·in) for use with Bench Stands	¼"
50252	5 - 50 N·m (5 - 50 lbf·ft) for use with Bench Stands	⅜"
50253	10 - 100 N·m (10 - 100 lbf·ft) for use with Bench Stands	½"
50254	100 - 700 N·m (100 - 500 lbf·ft) for use with Bench Stands	¾"
50693	10 – 140 N·m (10 – 100 lbf·ft) for use with STB1000	½"
50694	100 – 700 N·m (70 – 500 lbf·ft) for use with STB1000	¾"

INTRODUCTION

The Norbar Joint Simulator in conjunction with the Norbar Torque Transducers and instruments is designed to measure the torque output of power torque tools. This it does by simulating the working conditions of screwed or bolted joints.

Spring Washers can be arranged in various serial/parallel combinations to represent the working conditions as seen by the tool, i.e. joints of varying stiffness ('soft' or 'hard' pull up) and for a range of maximum torque outputs.

Refer to BS 6268, ISO 6544 and ISO 5393 for further details on torque tool rundown.

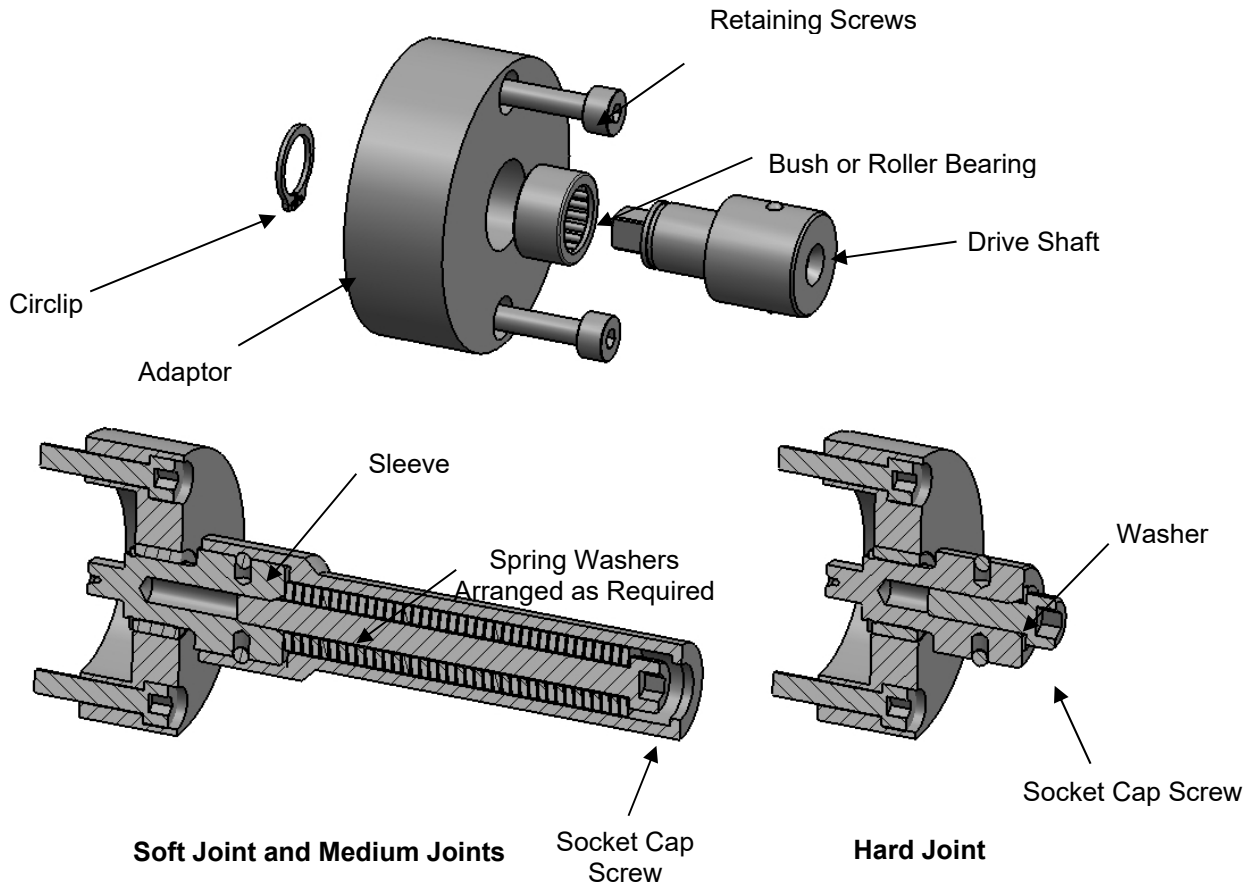
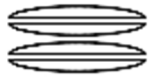

FIGURE 1 – Exploded View of Fixture Assembly

PART NUMBER 50313 (0.2 – 2 N·m, 2 – 25 lbf·in)

Washer arrangements for joint simulation



Washers in Series



Washers in Parallel

Washer Make Up For Various Joint Conditions

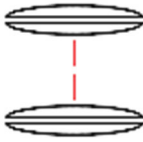
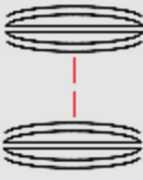
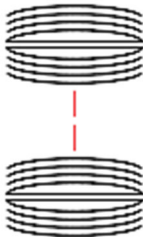
Washer Make Up	Torque Range
 <p data-bbox="507 622 901 660">72 Washers in series (STACK A)</p>	<p data-bbox="1037 611 1200 674">0.2 - 0.7 N·m (1.8 - 6 lbf·in)</p>
 <p data-bbox="531 813 877 875">40 Stacks of 2 washers in parallel, in series (STACK B)</p>	<p data-bbox="1018 813 1216 875">0.5 - 1.4 N·m (4.5 - 12.5 lbf·in)</p>
 <p data-bbox="531 1066 877 1128">20 Stacks of 4 washers in parallel, in series (STACK C)</p>	<p data-bbox="1034 1066 1200 1128">1.2 - 2.8 N·m (10 - 25 lbf·in)</p>

NOTE: Exceeding maximum torque for washer make-up will result in permanent damage to washers.
 Keep bolt and washers greased with a graphite loaded grease.
 Supplied with washer stack 'C'. Other stacks can be made up by rearranging stack 'C'.

For a 'hard' pull up condition, remove sleeve, long bolt and all spring washers and run down the short bolt and plain washers supplied.

Operation Procedure

Switch display instrument to required mode (see instrument operators manual for details).
 With selected arrangement of spring washers in fixture, run bolt down with tool and note torque output.
 Reverse tool to undo bolt ready for next test. Reset readout on display instrument as required.

Graph Showing Torque Rate Curves For Various Washer Make-Ups

Bolt Size: M6 x 80mm x 1.0 pitch, 12.9 socket cap screw, 5mm A/F

Washers: DIN 2093 - A12.5 (12.5mm x 6.2mm x 0.7mm)

Lubrication: Rocol M204 G Graphite grease or Rocol Tufgear 85.

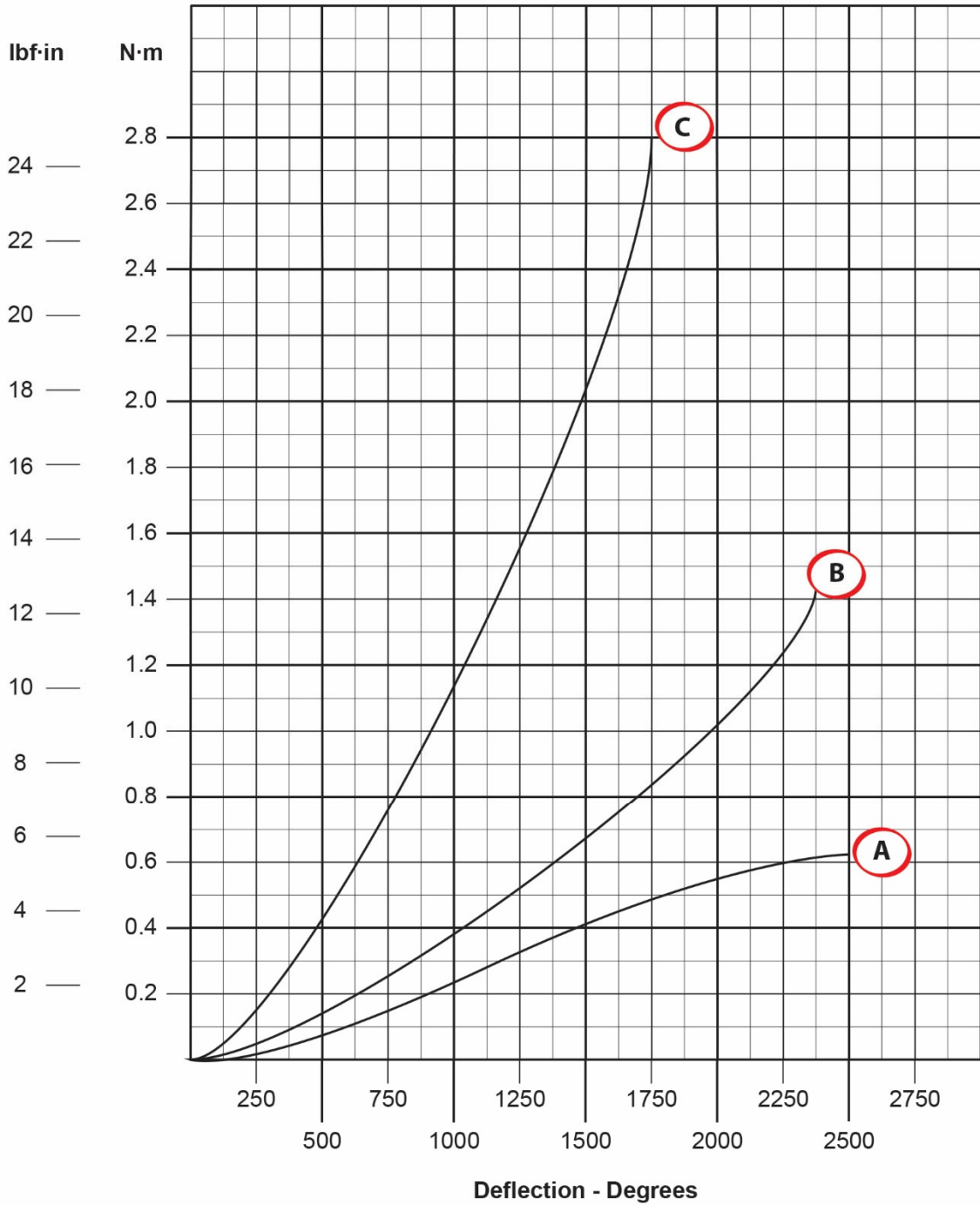

PART NUMBER 50251 (2 - 10 N·m, 20 – 100 lbf·in)

Washer arrangements for joint simulation



Washers in Series



Washers in Parallel

Washer Make Up For Various Joint Conditions

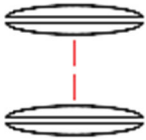
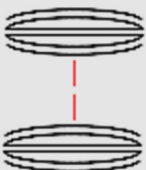
Washer Make Up	Torque Range
 <p data-bbox="507 611 903 645">40 Washers in series (STACK D)</p>	<p data-bbox="1038 600 1203 658">2 - 6 N·m (20 - 50 lbf·in)</p>
 <p data-bbox="533 797 877 855">21 Stacks of 2 washers in parallel, in series (STACK E)</p>	<p data-bbox="1029 797 1212 855">6 - 12 N·m (50 - 100 lbf·in)</p>

NOTE: Exceeding maximum torque for washer make-up will result in permanent damage to washers.
Keep bolt and washers greased with a graphite loaded grease.
Supplied with washer stack 'E'. Other stacks can be made up by rearranging stack 'E'.

For a 'hard' pull up condition, remove sleeve, long bolt and all spring washers and run down the short bolt and plain washers supplied.

Operation Procedure

Switch display instrument to required mode (see instrument operators manual for details).
With selected arrangement of spring washers in fixture, run bolt down with tool and note torque output.
Reverse tool to undo bolt ready for next test. Reset readout on display instrument as required.

Graph Showing Torque Rate Curves For Various Washer Make-Ups

Bolt Size: M6 x 1.00 Pitch, 12.9 socket cap screw

Washers: DIN 6796-6-FST (14mm x 6.4mm x 1.5mm)

Lubrication: Rocol M204 G Graphite Grease or Rocol Tufgear 85.

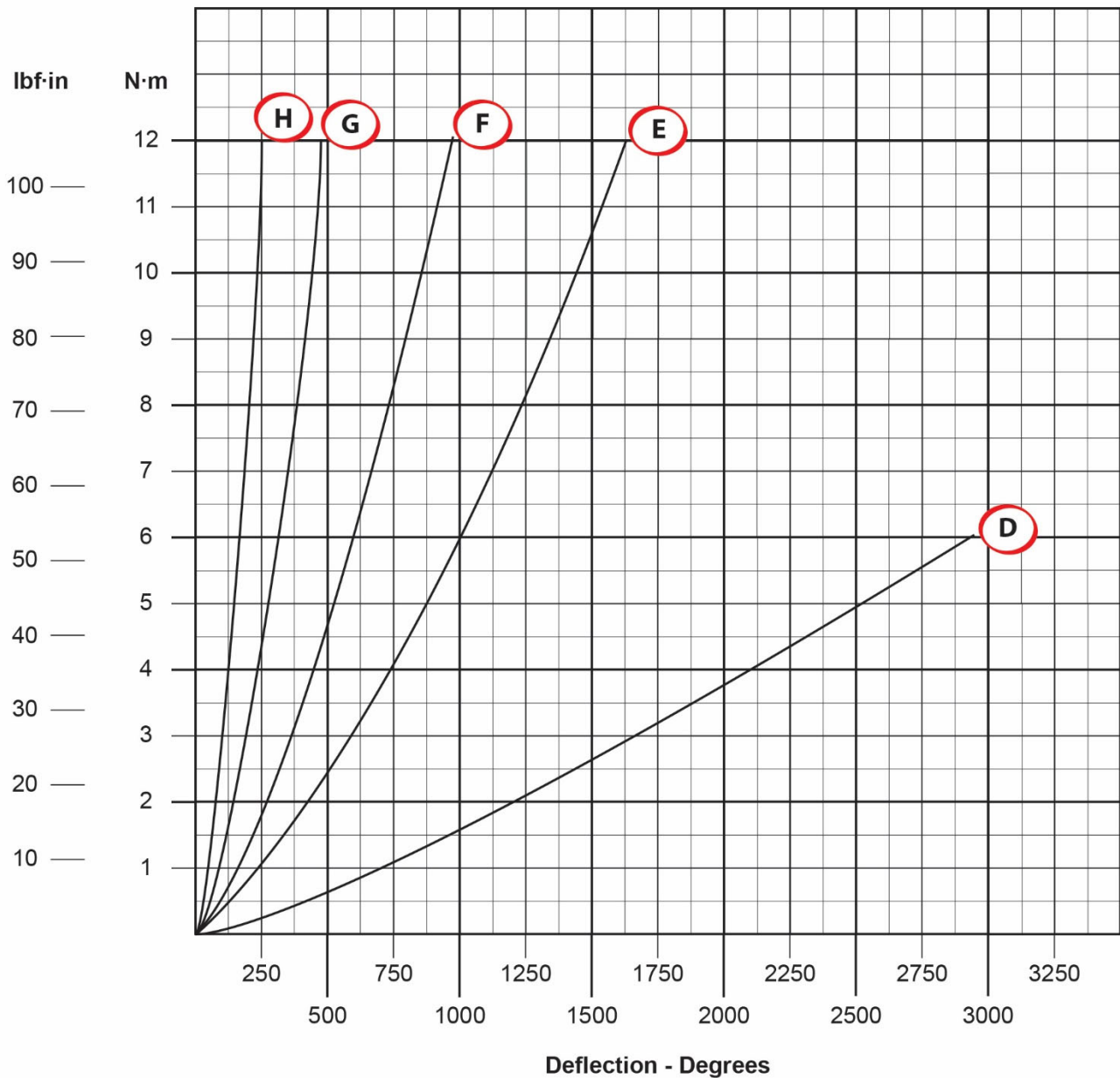

'D' 40 washers in series

'E' 21 stacks of 2 washers in parallel, in series

'F' 14 stacks of 3 washers in parallel, in series

'G' 7 stacks of 6 washers in parallel, in series

'H' 42 washers in parallel

NOTE: Washer make-ups 'D' and 'E' only for soft joint condition.
'F', 'G' and 'H' for intermediate joint condition.

PART NUMBER 50252 (5 – 50 N·m, 5 – 50 lbf·ft)

Washer arrangements for joint simulation

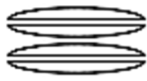

Washers in Series



Washers in Parallel

Washer Make Up For Various Joint Conditions

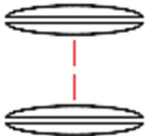
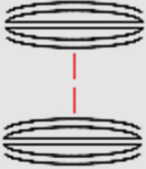
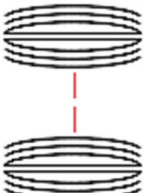
Washer Make Up	Torque Range
 <p data-bbox="507 611 903 645">36 Washers in series (STACK A)</p>	<p data-bbox="1046 600 1193 656">5 - 30 N·m (5 - 20 lbf·ft)</p>
 <p data-bbox="531 801 874 857">18 Stacks of 2 washers in parallel, in series (STACK B)</p>	<p data-bbox="1038 801 1201 857">20 - 50 N·m (15 - 35 lbf·ft)</p>
 <p data-bbox="531 1037 874 1093">12 Stacks of 3 washers in parallel, in series (STACK C)</p>	<p data-bbox="1038 1037 1201 1093">50 - 70 N·m (35 - 50 lbf·ft)</p>

NOTE: Exceeding maximum torque for washer make up will result in permanent damage to washers. Keep bolt and washers greased with a graphite loaded grease. Supplied with washer stack 'C'. Other stacks can be made up by rearranging stack 'C'.

For a 'hard' pull up condition, remove sleeve, long bolt and all spring washers and run down the short bolt and plain washers supplied.

Operation Procedure

Switch display instrument to required mode (see instrument operators manual for details). With selected arrangement of spring washers in fixture, run bolt down with tool and note torque output. Reverse tool to undo bolt ready for next test. Reset readout on display instrument as required.

Graph Showing Torque Rate Curves For Various Washer Make-Ups

Bolt Size: M10 x 1.25 pitch, 12.9 socket cap screw.

Washers: DIN 6796-10-FST (23mm x 10.5mm x 2.5mm)

Lubrication: Rocol M204 G Graphite grease or Rocol Tufgear 85.

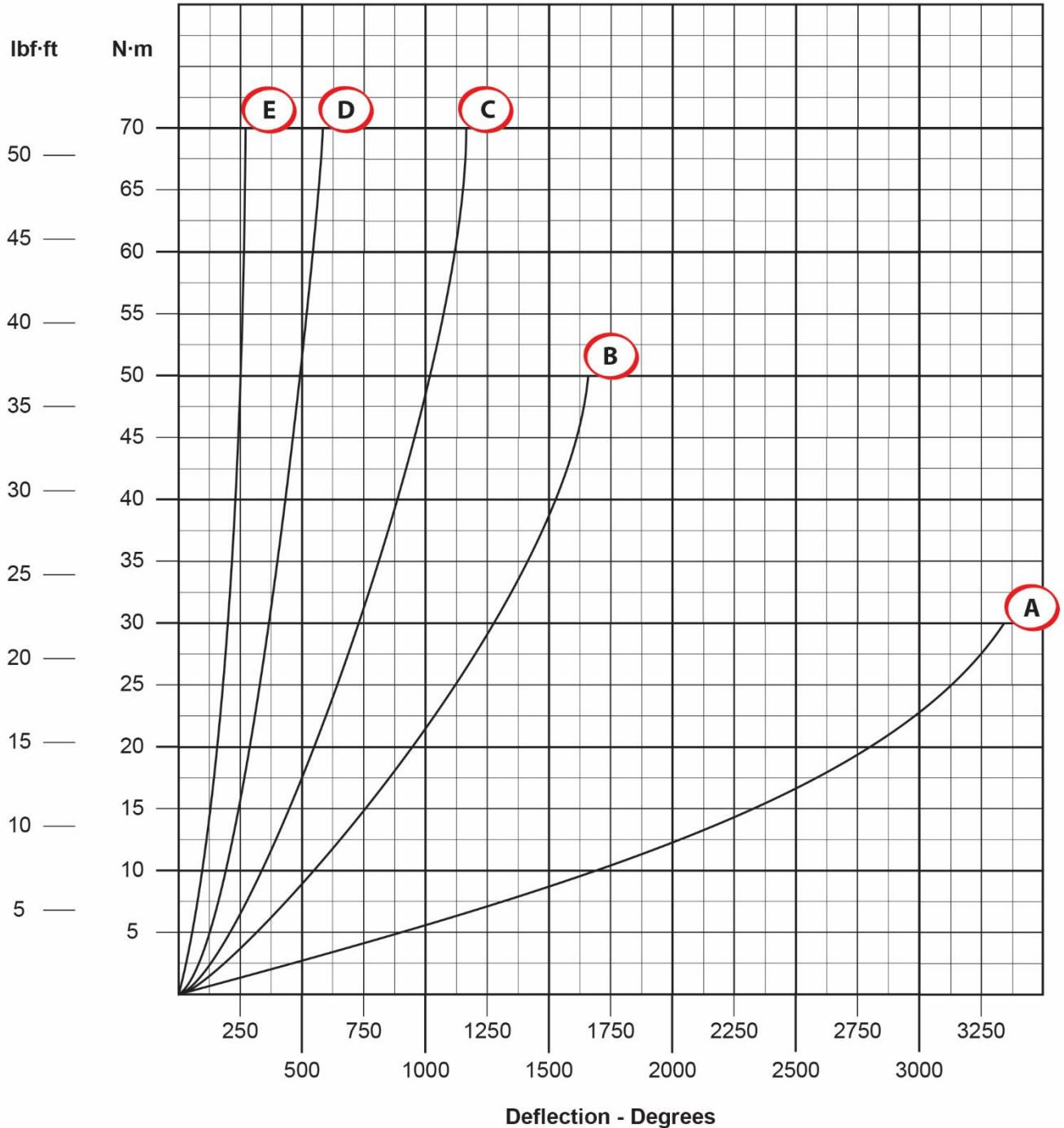

- 'A' 36 washers in series
- 'B' 18 stacks of 2 washers in parallel, in series
- 'C' 12 stacks of 3 washers in parallel, in series
- 'D' 6 stacks of 6 washers in parallel, in series
- 'E' 36 washers in parallel

NOTE: Washer make-ups 'A', 'B' and 'C' only for soft joint condition. 'D', 'E' for intermediate joint condition.

PART NUMBER 50253 & 50693 (10 - 140 N·m, 10 – 100 lbf·ft)

Washer arrangements for joint simulation

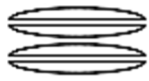

Washers in Series



Washers in Parallel

Washer Make Up For Various Joint Conditions

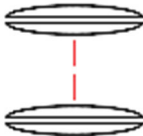
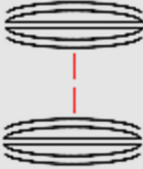
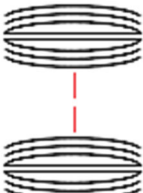
Washer Make Up	Torque Range
 <p data-bbox="507 611 903 645">28 Washers in series (STACK F)</p>	<p data-bbox="1038 600 1201 656">10 - 50 N·m (10 - 35 lbf·ft)</p>
 <p data-bbox="531 801 879 857">15 Stacks of 2 washers in parallel, in series (STACK G)</p>	<p data-bbox="1038 801 1201 857">30 - 100 N·m (25 - 70 lbf·ft)</p>
 <p data-bbox="531 1037 879 1093">10 Stacks of 3 washers in parallel, in series (STACK H)</p>	<p data-bbox="1034 1037 1206 1093">80 - 140 N·m (60 - 100 lbf·ft)</p>

NOTE: Exceeding maximum torque for washer make up will result in permanent damage to washers. Keep bolt and washers greased with a graphite loaded grease. 50253 and 50693 are supplied with washer stack 'H'. Other stacks can be made up by rearranging stack 'H'.

For a 'hard' pull up condition, remove sleeve, long bolt and all spring washers and run down the short bolt and plain washers supplied

Operation Procedure

Switch display instrument to required mode (see instrument operators manual for details). With selected arrangement of spring washers in fixture, run bolt down with tool and note torque output. Reverse tool to undo bolt ready for next test. Reset readout on display instrument as required.

Graph Showing Torque Rate Curves For Various Washer Make-Ups

Bolt Size: M12 x 1.25 pitch, 12.9 socket cap screw.

Washers: DIN 6786-12-FST (29mm x 13mm x 3mm)

Lubrication: Rocol M204 G Graphite grease or Rocol Tufgear 85.

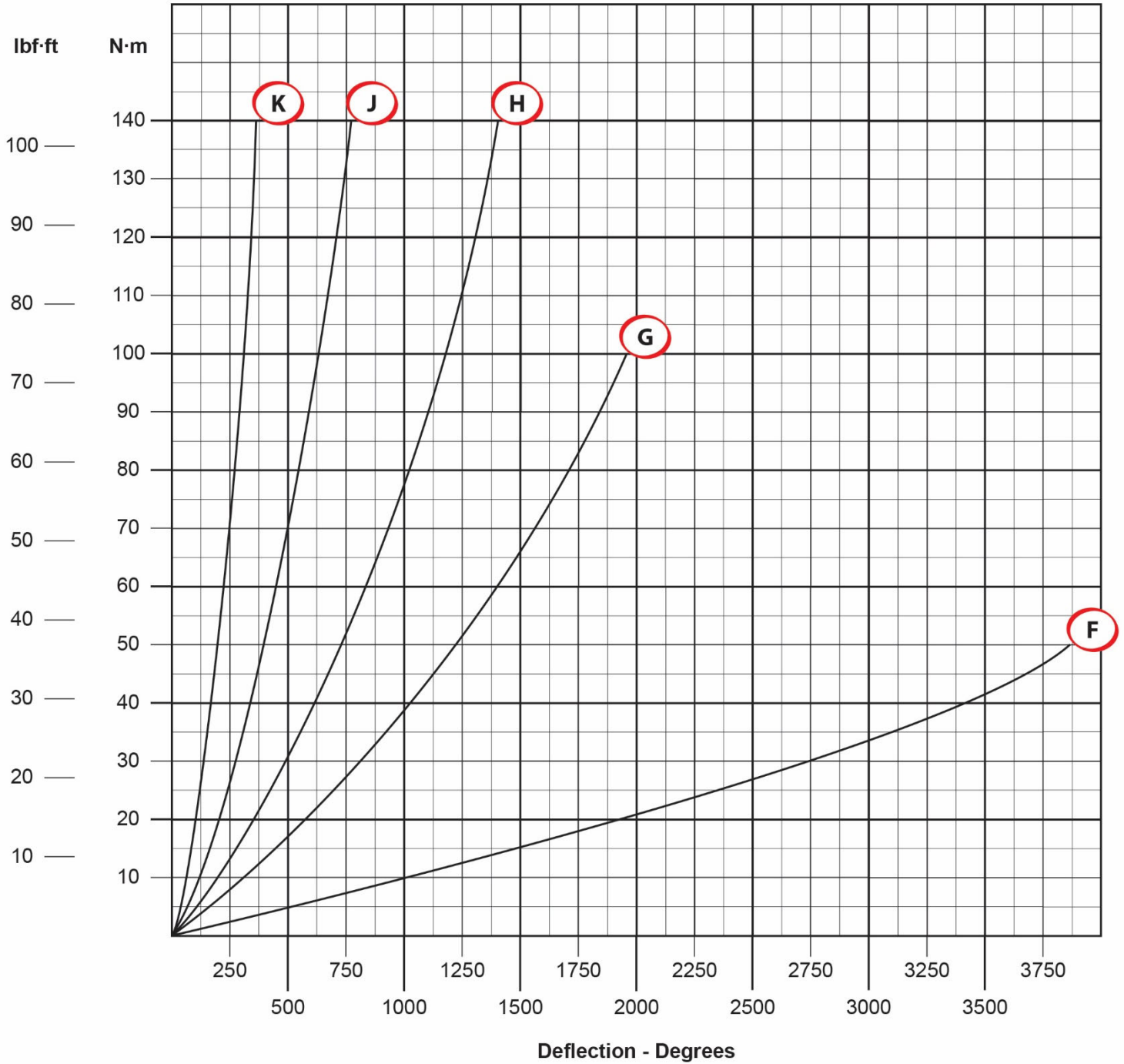

PART NUMBER 50254 50694 (100 - 700 N·m, 100 – 500 lbf·ft)

Washer arrangements for joint simulation



Washers in Series



Washers in Parallel

Washer Make Up For Various Joint Conditions

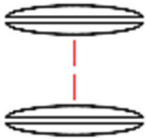
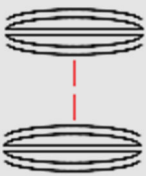
Washer Make Up	Torque Range
 <p data-bbox="507 609 903 640">30 Washers in series (STACK A)</p>	<p data-bbox="1024 595 1216 658">100 - 400 N·m (100 - 300 lbf·ft)</p>
 <p data-bbox="533 797 877 860">15 Stacks of 2 washers in parallel, in series (STACK B)</p>	<p data-bbox="1024 797 1216 860">350 - 700 N·m (250 - 500 lbf·ft)</p>

NOTE: Exceeding maximum torque for washer make-up will result in permanent damage to washers. Keep bolt and washers greased with a graphite loaded grease. 50254 and 50694 are supplied with washer stack 'B'. Other stacks can be made up by rearranging stack 'B'.

For a 'hard' pull up condition, remove sleeve, long bolt and all spring washers and run down the short bolt and plain washers supplied.

Operation Procedure

Switch display instrument to required mode (see instrument operators manual for details). With selected arrangement of spring washers in fixture, run bolt down with tool and note torque output. Reverse tool to undo bolt ready for next test. Reset readout on display instrument as required.

Graph Showing Torque Rate Curves For Various Washer Make-Ups

Bolt Size: M24 x 240mm long x 3mm pitch, 12.9 socket cap screw, 19mm A/F.

Washers: DIN 6796-24-FST (56mm x 25mm x 6mm).

Lubrication: Rocol M204 G Graphite grease or Rocol Tufgear 85.

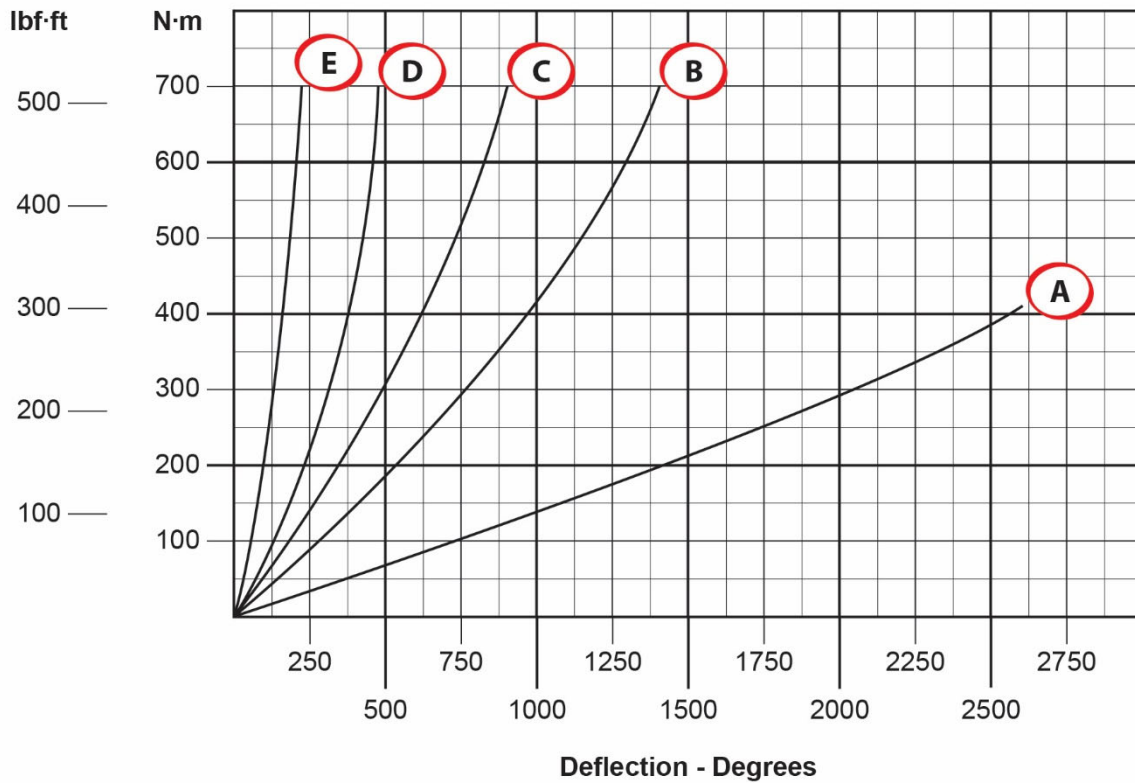

- 'A' 30 washers in series
- 'B' 15 stacks of 2 washers in parallel, in series
- 'C' 10 stacks of 3 washers in parallel, in series
- 'D' 6 stacks of 5 washers in parallel, in series
- 'E' 30 washers in parallel

NOTE: Washer make-ups 'A' and 'B' only for soft joint condition. 'C', 'D' and 'E' for intermediate joint condition.

BOLT AND HEX DRIVE SIZES

Part Number	Bolt Size	Hex Drive
50313	M6 x 1.0	5mm AF
50251	M6 x 1.0	5mm AF
50252	M10 x 1.0	8mm AF
50253, 50693	M12 x 1.25	10mm AF
50254, 50694	M24 x 3.0	19mm AF

SPARE WASHER STACKS

Part Number	Capacity	For Use With Joint Simulator
50175 (Washer Stack A)	0.2 – 0.7 N·m	50313
50176 (Washer Stack B)	0.5 – 1.4 N·m	50313
50177 (Washer Stack C)	1.2 – 2.8 N·m	50313
50178 (Washer Stack D)	2 – 6 N·m	50251
50179 (Washer Stack E)	6 – 12 N·m	50251
50695 (Washer Stack A)	5 – 30 N·m	50252
50696 (Washer Stack B)	20 – 50 N·m	50252
50697 (Washer Stack C)	50 – 70 N·m	50252
50180 (Washer Stack F)	10 – 50 N·m	50253, 50693
50192 (Washer Stack G)	30 – 100 N·m	50253, 50693
50698 (Washer Stack H)	80 – 140 N·m	50253, 50693

NORBAR TORQUE TOOLS LTD

Wildmere Road, Banbury,
Oxfordshire, OX16 3JU

UNITED KINGDOM

Tel + 44 (0)1295 270333

Email enquiry@norbar.com

For the most up-to-date
version of the Operator's
Manual, please scan the
QR code below.



To find your local
Norbar company or
distributor, please scan
the QR code below.



www.norbar.com